

## B-30 - Kolano



**B-30** - Kolano okrągłe 30° chemo odporne wykonane z tworzyw sztucznych

**Wykonanie:**

- kolano kąt 30°
- promień  $R = D$
- formowane maszynowo do 315mm
- formowane ręcznie od 355mm do 800mm
- wykonanie segmentowe powyżej 800mm
- minimalna grubość ścianki 3 mm lub zgodnie z DIN 4741
- zakończenia mufowe (M)
- łączenie przez klejenie/spawanie/skręcanie



## Dane techniczne

### Temperatura stosowania:

Tr [°C] jak dla materiału

### Temperatura pracy:

Tmax. [°C] jak dla materiału

### Ciśnienie pracy:

Pmax. [Pa] jak dla materiału

### Kolor:

jak dla materiału

### Wymiarowanie:

Kolano B [m] - 30 - [d]





[m] - typ materiału

[d] - średnica kanału wentylacyjnego w mm

### Uwagi:

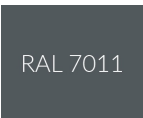
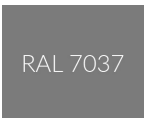
Kolana dostępne także w wersji 15°, 45°, 60°, 75° i 90°.

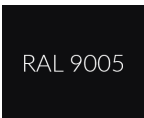
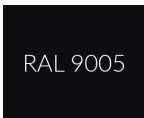
### Oznaczenie:

Typ	B1-30	B2-30	B3-30	B4-30	B5-30	B6-30	B9-30
<b>Materiał</b>	PVC-U	PPs	PP	PE	PPs-el	PVDF	PVC-UV
<b>Kolor</b>							
<b>Nazwa</b>	polichlorek winyłu	polipropylen samogasnący	polipropylen	polietylen	polipropylen samogasnący elektroprzewodzący	polifluorek winylidenu	polichlorek winyłu

## Wymiary

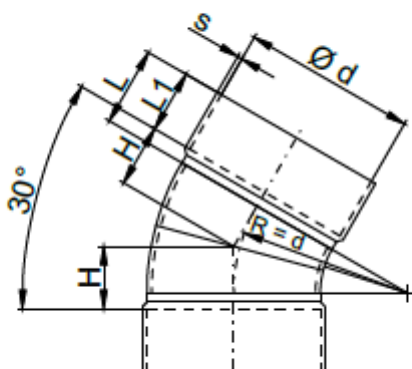

d [mm]	PVC-U / PVC-C					PP / PPs / PE / PPs-el / PVDF				
	L [mm]	L1 [mm]	H [mm]	s [mm]	m [kg]	L [mm]	L1 [mm]	H [mm]	s [mm]	m [mm]
<b>0050</b>	30	25	20	3,0	0,1	30	25	20	3,0	0,1
<b>0063</b>	30	25	20	3,0	0,1	30	25	20	3,0	0,1
<b>0075</b>	40	35	25	3,0	0,1	40	35	25	3,0	0,1
<b>0090</b>	40	35	30	3,0	0,1	40	35	30	3,0	0,1
<b>0110</b>	50	40	55	3,0	0,2	50	40	40	3,0	0,2
<b>0125</b>	50	40	60	3,0	0,2	50	40	45	3,0	0,2
<b>0140</b>	50	40	70	3,0	0,3	50	40	50	3,0	0,3
<b>0160</b>	50	40	65	3,0	0,3	50	40	55	3,0	0,3
<b>0180</b>	60	50	85	3,0	0,4	60	50	60	3,0	0,4
<b>0200</b>	60	50	85	3,0	0,5	60	50	65	3,0	0,5
<b>0225</b>	60	50	105	3,5	0,6	60	50	70	3,5	0,6
<b>0250</b>	60	50	105	3,5	0,8	60	50	75	4,0	0,7
<b>0280</b>	60	50	125	3,0	0,9	60	50	85	4,0	1,0
<b>0315</b>	60	50	140	3,0	1,4	60	50	95	5,0	1,4
<b>0355</b>	60	50	155	3,0	1,6	60	50	105	5,0	1,7
<b>0400</b>	70	60	175	3,0	1,9	70	60	120	6,0	2,7

<b>d [mm]</b>	<b>PVC-U / PVC-C</b>					<b>PP / PPs / PE / PPs-el / PVDF</b>				
<b>0450</b>	70	60	195	3,5	3,4	70	60	135	6,0	4,1
<b>0500</b>	70	60	215	4,0	3,9	70	60	155	6,0	4,8
<b>0560</b>	-	-	-	-	-	110	90	170	6,0	5,1
<b>0600</b>	80	70	170	5,0	5,6	-	-	-	-	-
<b>0630</b>	-	-	-	-	-	110	90	190	8,0	7,5
<b>0700</b>	110	90	210	6,0	14,0	-	-	-	-	-
<b>0710</b>	-	-	-	-	-	110	90	210	8,0	8,9
<b>0800</b>	120	100	235	7,0	18,0	120	100	235	10,0	18,5
<b>0900</b>	130	110	265	8,0	27,3	130	110	265	8,0	23,5
<b>1000</b>	130	110	265	8,0	37,7	130	110	265	8,0	35,2