

## B-75 - Kolano



**B-75** - Kolano okrągłe 75° chemoodporne wykonane z tworzyw sztucznych

**Wykonanie:**

- kolano kąt <75°
- promień  $R = D$
- formowane maszynowo do 315mm
- formowane ręcznie od 355mm do 800mm
- wykonanie segmentowe powyżej 800mm
- minimalna grubość ścianki 3 mm lub zgodnie z DIN 4741
- zakończenia mufowe (M)
- łączenie przez klejenie/spawanie/skręcanie



## Dane techniczne

### Temperatura stosowania:

Tr [°C] jak dla materiału

### Temperatura pracy:

Tmax. [°C] jak dla materiału

### Ciśnienie pracy:

Pmax. [Pa] jak dla materiału

### Kolor:

jak dla materiału

### Wymiarowanie:

Kolano B [m] - 75 - [d]

[m] - typ materiału

[d] - średnica kanału wentylacyjnego w mm

### Uwagi:

Kolana dostępne także w wersji 15°, 30°, 45°, 60°, 90°.

### Oznaczenie:

Typ	B1-75	B2-75	B3-75	B4-75	B5-75	B6-75	B9-75
<b>Materiał</b>	PVC-U	PPs	PP	PE	PPs-el	PVDF	PVC-UV
<b>Kolor</b>	 RAL 7011	 RAL 7037	 RAL 7032	 RAL 9005	 RAL 9005	 NATURAL	 RAL 9016
<b>Nazwa</b>	polichlorek winyłu	polipropylen samogasnący	polipropylen	polietylen	polipropylen samogasnący elektroprzewodzący	polifluorek winylidenu	polichlorek winyłu

## Wymiary

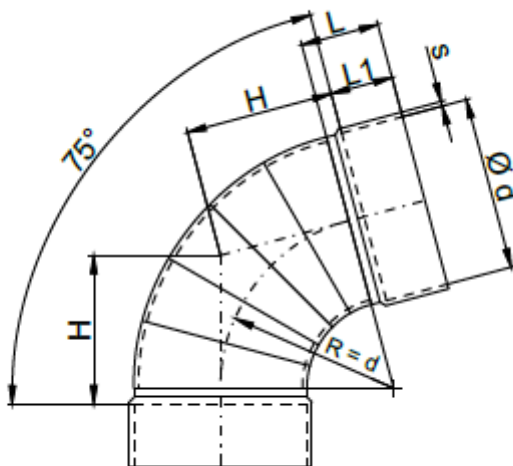

d [mm]	PVC / PVC-UV					PP / PPs / PE / PPs-el / PVDF				
	L [mm]	L1 [mm]	H [mm]	s [mm]	m [kg]	L [mm]	L1 [mm]	H [mm]	s [mm]	m [kg]
<b>0050</b>	30	25	50	3,0	0,1	30	25	45	3,0	0,1
<b>0063</b>	30	25	60	3,0	0,1	30	25	55	3,0	0,1
<b>0075</b>	40	35	65	3,0	0,1	40	35	65	3,0	0,1
<b>0090</b>	40	35	75	3,0	0,1	40	35	75	3,0	0,2
<b>0110</b>	50	40	95	3,0	0,2	50	40	95	3,0	0,3
<b>0125</b>	50	40	105	3,0	0,4	50	40	105	3,0	0,3
<b>0140</b>	50	40	115	3,0	0,4	50	40	115	3,0	0,4
<b>0160</b>	50	40	135	3,0	0,5	50	40	135	3,0	0,5
<b>0180</b>	60	50	150	3,0	0,6	60	50	150	3,0	0,6
<b>0200</b>	60	50	165	3,0	0,8	60	50	165	3,0	0,8
<b>0225</b>	60	50	185	3,5	1,0	60	50	185	3,5	1,0
<b>0250</b>	60	50	200	3,5	1,4	60	50	200	4,0	1,3
<b>0280</b>	60	50	225	3,5	1,6	60	50	225	4,0	1,8
<b>0315</b>	60	50	250	3,5	2,4	60	50	250	5,0	2,7
<b>0355</b>	60	50	280	3,5	2,8	60	50	280	5,0	3,3
<b>0400</b>	70	60	315	3,5	3,7	70	60	320	6,0	5,0

d [mm]	PVC / PVC-UV					PP / PPs / PE / PPs-el / PVDF				
<b>0450</b>	70	60	365	3,5	5,8	70	60	360	6,0	5,7
<b>0500</b>	70	60	405	4,0	8,0	70	60	405	6,0	7,5
<b>0560</b>	-	-	-	-	-	110	90	450	6,0	9,1
<b>0600</b>	80	70	470	5,0	12,0	80	70	470	8,0	-
<b>0630</b>	-	-	-	-	-	110	90	485	8,0	11,6
<b>0700</b>	110	90	565	6,0	22,0	110	90	565	8,0	-
<b>0710</b>	-	-	-	-	-	110	90	565	8,0	19,0
<b>0800</b>	120	100	630	7,0	28,0	120	100	630	10,0	33,0
<b>0900</b>	130	110	795	8,0	50,3	130	110	795	8,0	43,2
<b>1000</b>	130	110	795	8,0	66,8	130	110	795	8,0	58,5